



A 6-Gb/s CMOS Imaging Diversity Receiver Front-End Employing Select-Best Method

Yiling Zhang, Valencia Joyner

Department of Electrical and Computer Engineering
Tufts University



Shengling Deng, Zhaoran Huang

Department of Electrical, Computer and Systems Engineering
Rensselaer Polytechnic Institute

Introduction

Optical wireless (OW) communication links are emerging as a promising broadband wireless access technology in terms of **high data rate, high power efficiency, low transceiver complexity, networking security, and unregulated bandwidths**

Imaging diversity receiver configurations employing select-best combination can achieve high optical gain over a wide field-of-view (FOV) and significantly reduce the effects of ambient light noise, cochannel interference and multipath distortion

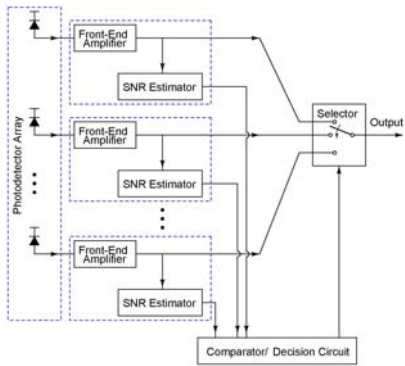

Select-Best Imaging Diversity Receiver Architecture

Select-Best Imaging Diversity Receiver Circuits

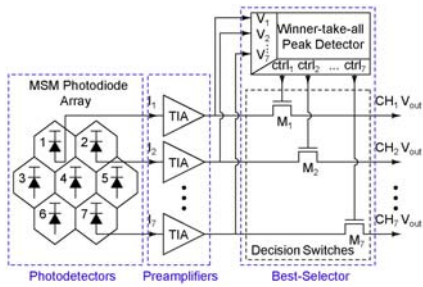

The receiver circuits consist of a seven channel transimpedance amplifier array and a select-best diversity combining circuit utilizing a winner-take-all peak detector. The select-best circuit monitors the channel output SNR and selects the channel with the highest SNR, shunting off the output of other channels.

Front-End Transimpedance Amplifier

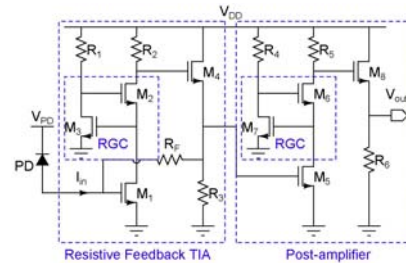

Regulated Cascode (RGC) topology effectively reduces the Miller effect

Simulation Results of Transimpedance Amplifier

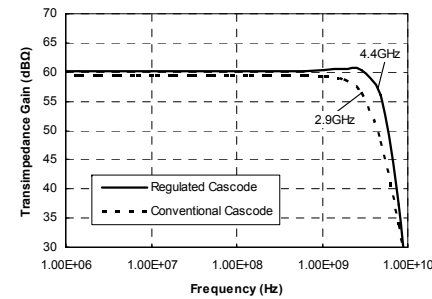

DC Gain=60.2dBΩ Bandwidth=4.4GHz

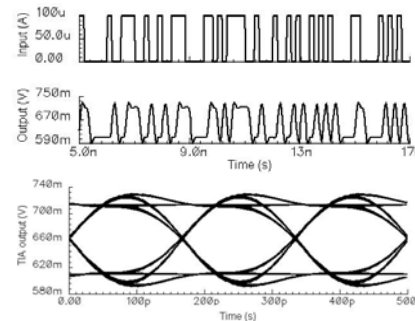

Transient response and eye diagram of the single channel TIA at 6Gbit/s input data rate. The 100uA peak-peak input current is patterned by a $2^{16}-1$ pseudorandom binary sequence (PRBS)

Winner-Take-All (WTA) Best-Selector

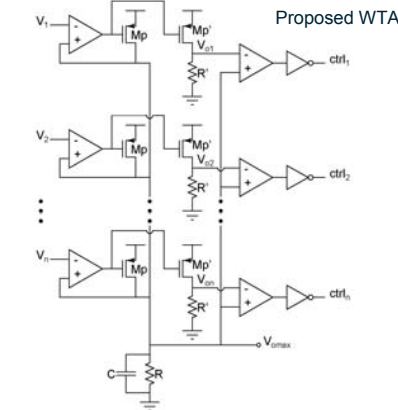
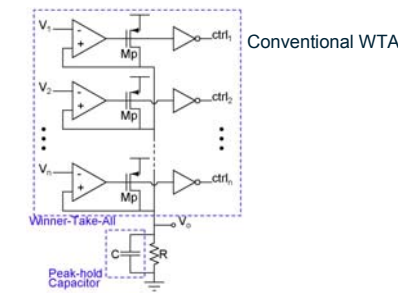

The proposed WTA structure adds a replica stage (M_p' and R') and another comparator to each channel of a conventional WTA. If R' is chosen to be $2R$, V_{omax} works as a self-generated reference voltage to identify the maximum input channel.

Select-Best Performance

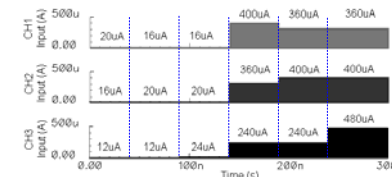

The channel with maximum input photocurrent signal alternates between CH1, CH2, and CH3. The input photocurrent amplitude to each channel at each time slot is annotated above.

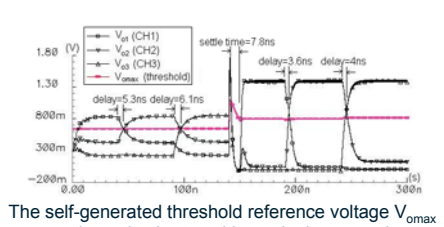

The self-generated threshold reference voltage V_{omax} accurately tracks the transition point between the high level and low level replica stage output voltages for both small amplitude inputs and large amplitude inputs.

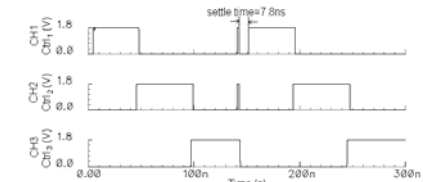

Max identification digital output from the WTA. The alternative shift of the high logic level corresponds to the alternative shift of the maximum input channel.

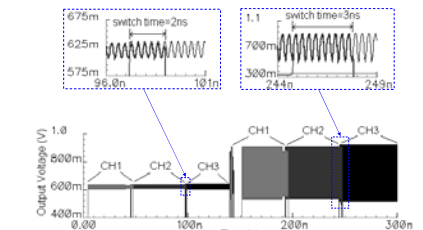

Outputs from these three channels displayed on a single coordinate. It is seen that for each time slot only the channel with maximum photocurrent amplitude has an output.

Summary of Performance

Technology	IBM 180nm CMOS	
TIA DC Gain	60.2dBΩ	
TIA Bandwidth	4.4GHz @ 250fF	
TIA Input Referred Noise	21pA/√Hz @ 250fF	
WTA Resolution	2μA @ 20μA Input current 4μA @ 400μA Input current	
Power Dissipation from 1.8V supply	Single TIA	8.2mW
	Best-Selector	26.6mW
	Total power for seven channels	172mW