

Optical Study of the Skeletal Muscle During Exercise with a Second Generation Frequency-Domain Tissue Oximeter

Maria Angela Franceschini^a, Don Wallace^b, Beniamino Barbieri^b, Sergio Fantini^a, William W. Mantulin^a, Simone Pratesi^c, Gian Paolo Donzelli^c, and Enrico Gratton^a

^aLaboratory for Fluorescence Dynamics, Department of Physics,
University of Illinois at Urbana-Champaign, Urbana, IL, 61801-3080

^bISS, Inc., Champaign, IL 61821

^cDepartment of Pediatrics, University of Florence, Italy 50132

ABSTRACT

We present a re-engineered frequency-domain tissue oximeter operating in the near-infrared spectral region. This instrument is based on the multi-distance measurement protocol, which we have implemented in our original design by multiplexing multiple light sources. The new instrument uses intensity modulated (110 MHz) laser diodes emitting at 750 and 840 nm. The laser diodes are coupled to glass optical fibers (600 μm core diameter). The average light intensity delivered to the tissue is about 3 mW. The multiplexing electronics are based on solid state switches that allow for acquisition times per point as short as tens of milliseconds. Our tests on phantoms and *in vivo* with the new oximeter have shown significant improvement in terms of stability, reliability, and reproducibility with respect to the original prototype. Furthermore, by using optical fibers we achieve a high versatility in the design of the measuring probe, permitting custom design for various tissue contours and different measurements. To verify the improved performance of the new oximeter, we have performed an *in vivo* test consisting of monitoring the hemoglobin saturation (Y) and concentration (THC) on the calf of 18 healthy volunteers during walking and running routines.

Keywords: near-infrared spectroscopy, hemoglobin saturation, tissue oximetry, skeletal muscle

1. INTRODUCTION

In 1994 we developed a frequency-domain spectrometer for the optical study of biological tissues.¹ This instrument, which is based on a multi-distance measurement protocol,² quantitatively measures the absorption (μ_a) and reduced scattering (μ_s') coefficients of the investigated tissue at two near-infrared wavelengths. This measurement is based on the acquisition of both intensity and phase data at multiple source-detector separations. The simultaneous measurement of μ_a and μ_s' constitutes the main novelty with respect to previous tissue oximeters. No assumptions are required about the photon path length or the scattering properties of the tissue. The separation of the absorption and scattering contributions to the attenuation of light in turbid media has been accomplished also by other methods such as steady state multi-distance,^{3,4} frequency-domain multi-frequency,⁵ and time-domain measurements.⁶ The frequency-domain multi-distance approach holds appeal in tissue oximetry for several reasons:

- 1) In contrast to the steady state approach, the measurement of absolute values can be done at relatively large source-detector separations (a few centimeters). The photon penetration depth is thus adequate to investigate tissues below the skin layer.
- 2) Since μ_a and μ_s' are derived from the relative readings collected at different source-detector separations, any effect that influences those readings to the same extent will cancel. For example, drifts in the signals sent to the light sources and/or to the optical detector by the power supplies have no influence on the measurement of the optical coefficients.
- 3) The instrumentation is relatively compact and cost-effective. It does not require the wide frequency range necessary for multi-frequency studies, or the short laser pulses and sophisticated detection methods used in the time-domain.
- 4) Real time monitoring is feasible since the acquisition times can be shorter than a second.

The absolute values of hemoglobin concentration and saturation can be derived from the absorption coefficients at the two wavelengths. The instrument works under two main assumptions: (*i*) Hemoglobin is the dominant absorber in tissues in the

spectral region considered (700-850 nm); (ii) The investigated tissue is macroscopically homogeneous. The first assumption is often well satisfied. The software of the instrument corrects for the small contribution of the absorption of water.⁷ The second assumption is more critical, especially for an instrument based on a multi-distance approach. Based on preliminary measurements, we believe that this assumption is fulfilled when large muscle volumes are investigated.

The first generation prototype, used eight light emitting diodes (LED's) (four with peak wavelength at 715 nm, four with peak wavelength at 825 nm) which were mounted directly on the measuring probe in contact with the skin. The distances between the light sources and the detection optical fiber ranged from 1.5 to 3.5 cm, yielding a photon penetration depth into the tissue in the approximate range 0.5-2 cm. The LED's were sinusoidally modulated at a frequency of 110 MHz, and turned on and off in sequence by means of mechanical relays. The optical detector is a photomultiplier tube (Hamamatsu Photonics R928) whose high voltage supply is typically 800 V in the *in vivo* measurements. This first generation prototype was tested in several laboratories, and it was used for measurements on phantoms^{1,8} and *in vivo*.⁹⁻¹³ Together, these measurements provided encouraging results and yielded valuable information about technical and practical limitations of the instrument. These limitations have been carefully considered by us, leading to the development of a second generation instrument. In this paper, we describe the limitations of the first prototype, and the solutions implemented in the new prototype to overcome them. As a test of the new prototype, we present *in vivo* data collected on the calf of 18 healthy subjects during walking and running exercises on a treadmill.

2. THE DEVELOPMENT OF THE NEW FREQUENCY-DOMAIN TISSUE OXIMETER

2.1. Strengths and weaknesses of the initial design

The results obtained with the initial prototype confirmed the effectiveness of the frequency-domain multi-distance approach in the optical study of tissues. The measured changes in hemoglobin saturation and concentration were in agreement with the readings of steady state oximeters, but in addition to that, the frequency-domain technique afforded quantitative readings of absolute values of these parameters.¹³ The quantitative values correlated well with invasive measurements based on drawing arterial and venous blood.¹¹ The instrumentation was extremely compact, thus allowing for measurements at the bed side. On the basis of these initial results, we have kept the basic design. In re-engineering the instrument to improve performance, we have focused our attention on the practical and technical limitations that were identified. The issues we have focused on include:

- (1) Stability of the optical signal;
- (2) Adequate signal to noise;
- (3) Reproducibility of the calibration procedure;
- (4) Ease of application of the measuring probe.

Many of these problems were related to our initial choice of light emitting diodes (LED's) as light sources, and to the design of their driving electronics. The average optical power emitted by the LED's (~300 μ W) was at the limit of what is needed to obtain measurable signals at source-detector separations of 3 cm or more. In tissues showing higher-than-average absorption, we had problems associated with the low signal level. In these conditions, we could not couple the LED's to optical fibers, since this would have introduced additional losses and even less optical power delivered by the fiber to the tissue. Having the LED's directly in contact with the skin, in turn caused more difficulties:

- (a) The measuring probe was bulky and rigid and there was not much latitude for design improvement;
- (b) It was necessary to deliver the radio frequency (RF) signal (110 MHz) to the measuring probe via an RF cable. Even though the cable was shielded, radio frequency pick up and changes in the transmitted signal due to subject movement caused significant disturbances;
- (c) The investigated tissue was not electrically isolated from the LED's driving electronics (especially when LED's with a metallic case were used);
- (d) The shape of the LED's accounted for a lack of reproducibility in the calibration procedure.

The calibration procedure, which is described in Ref. 1, consists of positioning the probe on a medium with known optical properties. The software calculates the corrective factors for the dc, ac, and phase of each light source to account for the variability in the outputs of the different light sources (were their outputs exactly equal, the calibration procedure would not be needed). The calibration procedure was not highly reproducible when we used LED's. The difference in the corrective factors calculated in repeated positionings of the probe on the calibration block, accounted for an error of about 10-15% in the absolute readings of the optical coefficients but, of course, not in the relative changes of the readings.

2.2. The new design

As a result of the effectiveness of the measurement protocol, the multi-distance approach based on multiplexing multiple light sources has been maintained in the new prototype. The main changes involve the introduction of fiber-coupled laser diodes, and newly designed driving electronics.

In the new prototype, we use eight laser diodes, four emitting at 750 nm (Sharp LT030MD), and four emitting at 840 nm (Sharp LT011MS). The laser diodes are coupled to glass optical fibers (600 μm core diameter) by means of SMA connectors. The outputs of the laser diodes corresponding to the shortest source-detector separations are attenuated by means of neutral density filters. In this fashion, we collect a comparable signal from all of the laser diodes. The higher optical power emitted by the laser diodes, together with a better fiber coupling efficiency, results in an optical power of about 3 mW delivered to the tissue (about one order of magnitude larger than what we had with LED's). Delivering the light signal by fiber optics also allows us to keep all the electronics and RF signals inside a well shielded box, which results in a higher signal stability. Furthermore, there is a higher degree of flexibility in the design of the measuring probe, since it now involves only fiber optics. The calibration procedure turns out to be more reproducible as a result of the uniform geometry of the eight fibers in the probe. The systematic error in the absolute readings of the optical coefficients introduced by the calibration procedure is now reduced to about 5% from 10-15% for the LED system.

Among the changes in the light source driving electronics, we note the use of TTL switches, instead of mechanical relays, to turn the various sources on and off. This modification allows us to achieve faster switching times, so that the ON time is now limited by the protection circuit which turns on the laser diodes (~ 3 ms). Taking advantage of this opportunity, we have increased the cross-correlation frequency to 5 KHz (in the past we used cross-correlation frequencies in the range 400 - 1250 Hz). Fast acquisition times on the order of 100 ms are now possible. We have also changed the way in which the various light sources are turned on during the acquisition time. In the past, we simply had each of the eight LED's on for 1/8 of the acquisition time. Now, we always keep each laser diode on for 100 periods of the cross-correlation signal (i.e. 20 ms for the 5 KHz cross-correlation frequency). In this way, for the case of eight laser diodes, we have a minimum acquisition time of 160 ms (one cycle). Longer acquisition times are obtained by combining more cycles. Figure 1 shows schematic diagrams for the old and new prototypes.

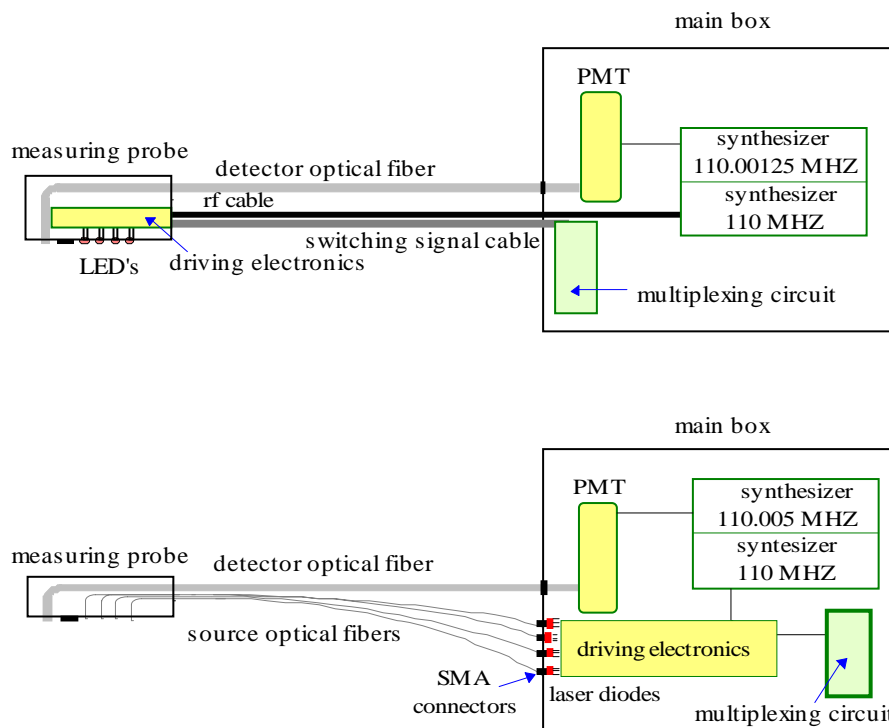

Fig. 1. Schematic diagrams of the (a) old and (b) new prototypes of the frequency-domain tissue oximeter. Note that in the new design (panel (b)), the light sources (laser diodes) and the driving electronics are located inside the main box, and optical fibers deliver the light to the measuring probe. In the old design (panel (a)), the light sources (LED's) were directly mounted on the measuring probe, which also contained the driving electronics.

3. TEST ON PHANTOMS

Figure 2 shows a comparison of the extent of signal fluctuation between the signals collected with the old and new prototypes over a 35-minute time period. The measurements were conducted on two samples (labeled “sample 1” and “sample 2” in the figures) having different optical properties. This explains the different absolute values recorded. The signal fluctuations is what we want to compare here. The acquisition time is the same for both prototypes (2.56 seconds per point). The dc intensity (Fig. 2(a)) is more stable in the new prototype. The point-to-point fluctuation is 0.1%, versus 0.5% for the old prototype. More importantly, there is only a constant drift (which usually disappears after the instrument warms up), and there are no jumps or changes in the trend. The phase (Fig. 2(b)) shows a similar effect. The point-to-point fluctuation is now comparable in the two instruments (~ 0.2 degrees) but the signal is more stable in the new prototype. The calculated plots of μ_a (Fig. 2(c)) and μ_s' (Fig. 2(d)) show the improvement achieved with the new design.

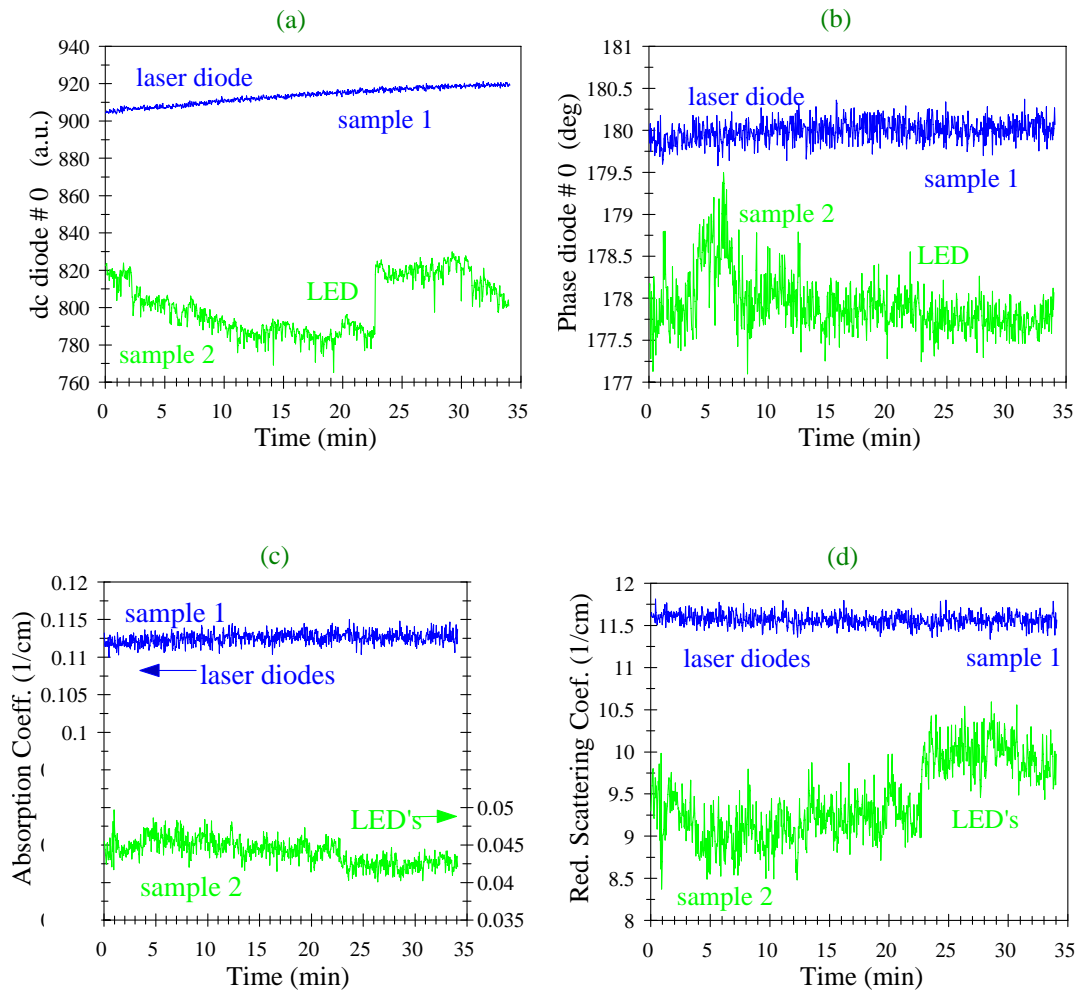

Fig. 2. Stability test performed with the old (LED's) and new (laser diodes) prototypes. The measurements were conducted on two different samples (labeled “sample 1” and “sample 2” in the figures), so that the absolute values of the readings cannot be compared. These figures compare the signal fluctuations for the (a) dc intensity, (b) phase, (c) absorption coefficient, and (d) reduced scattering coefficient. The new instrument shows a higher signal stability with respect to the old prototype.

4. TEST *IN VIVO*

To test the new frequency-domain tissue oximeter *in vivo*, we performed a set of measurements on the calf of 18 healthy subject (12 males, average age 34; 6 females, average age 33; all Caucasian). The measuring probe was kept in place by elastic bands and the instrumental readings were monitored during walking (speed: ~ 2.1 miles per hour), and running (speed: ~ 4.2 miles per hour) exercises on a flat treadmill. 12 subjects performed both walking and running exercises, 2 subjects performed only the walking, and 4 subjects performed only the running exercise. Acquisition time per data point was set to 1.28 s. The routine consisted of acquiring a baseline for 3 minutes, then the walking (running) exercise was started and lasted 6 (3) minutes. Finally, the recovery was followed for about 10 minutes with the subject always standing up. Typical traces of hemoglobin saturation (Y) and total hemoglobin concentration (THC) are shown in Fig. 3. The “baseline” and “exercise” parameters are indicated in the figures for both the walking and running routines, while the differences ΔY and ΔTHC (“exercise” – “baseline”) are shown in the figures for the running routine (Figs. 3(b) and 3(d)).

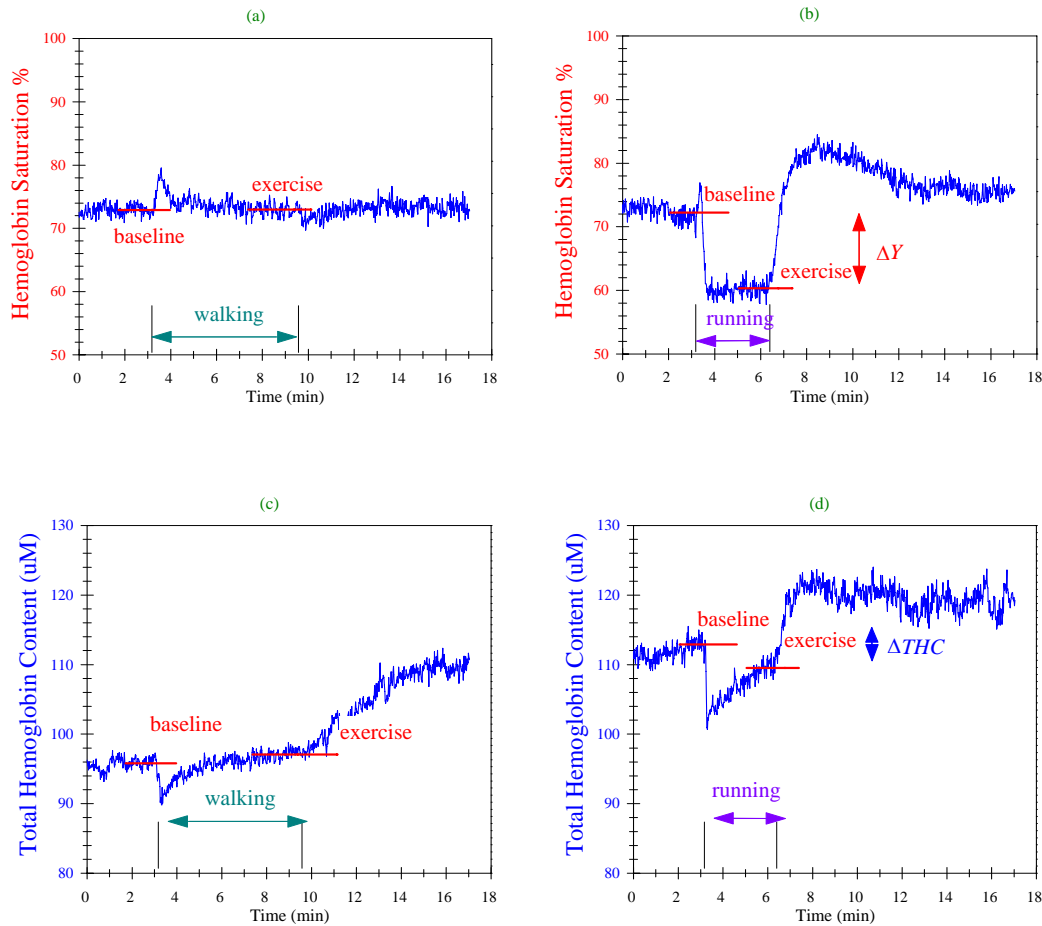

Fig. 3. Typical traces obtained for Y (upper panels: (a) and (b)) and THC (lower panels: (c) and (d)) during the walking (left panels: (a) and (c)) and running (right panels: (b) and (d)) routines. The duration of the exercise is indicated in the figures, as well as the baseline and exercise values obtained from the recorded traces. The variations ΔY and ΔTHC (“exercise” - “baseline”) are also indicated in the figures for the running routine (right panels). The protocol of the *in vivo* test consisted in performing the running routine right after the walking routine. This explains the higher baseline value of the THC in panel (d) with respect to the baseline value in panel (c).

The hemoglobin saturation typically reached a *plateau* during exercise (see Figs. 3(a) and (b)). By contrast, the total hemoglobin concentration did not always reach a *plateau*, and in those cases we have taken the value at the end of the exercise as the “exercise” value, as indicated in Figs. 3(c) and (d).

Table I shows the average and standard deviations of the baseline, walking, and running values of Y and THC , over the 18 subjects (14 for the walking routine, 16 for the running routine).

Table I. Values of the physiological parameters collected in the *in vivo* study.

	males			females		
	baseline	walking exercise	running exercise	baseline	walking exercise	running exercise
Y	71±3 %	69±3 %	57±7 %	72±3 %	69±3 %	64±4 %
THC	105±17 μM	103±15 μM	111±19 μM	56±8 μM	53±11 μM	59±12 μM

Figure 4 shows the changes in Y and THC for both the walking and running routines. The physiological information collected in this *in vivo* test indicates that the hemoglobin saturation decreases from the baseline value during exercise. The decrease during the walking routine ($-2\pm 2\%$ for males; $-4\pm 3\%$ for females) is considerably less than during the running routine ($-15\pm 7\%$ for males; $-9\pm 4\%$ for females). By contrast, the total hemoglobin concentration shows both positive and negative variations during the exercise. The absolute value of the variation is $5\pm 6\ \mu\text{M}$ for males, $7\pm 3\ \mu\text{M}$ for females during walking, and $7\pm 6\ \mu\text{M}$ for males, $5\pm 7\ \mu\text{M}$ for females during running. The changes of Y and THC during exercise with respect to the baseline values are reported in the histograms of Fig. 4. We are in the progress of analyzing this physiological information in more detail to better understand its relevance and its implications.

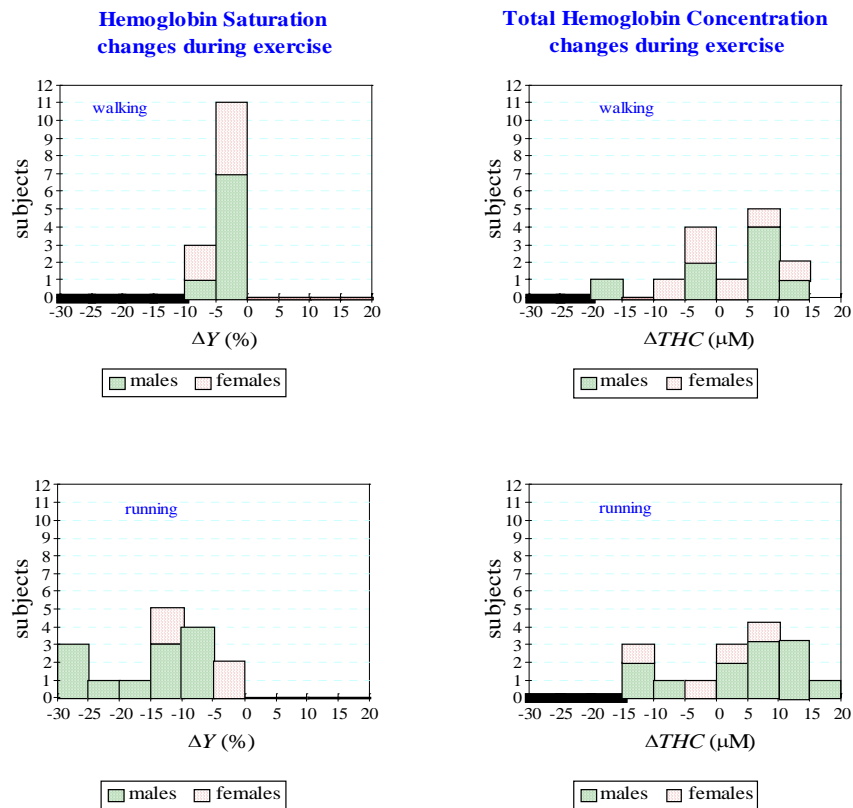

Fig. 4. Changes in the hemoglobin saturation (left panels) and concentration (right panels) during the walking (upper panels) and running (lower panels) routines. These histograms report the number of subjects showing a change in the measured parameter within the range reported below each one of the bars. The total number of subjects for the walking exercise was 14, while for the running exercise it was 16.

5. DISCUSSION

In conducting this *in vivo* test we experienced the significant practical improvements achieved with the new prototype. The optical coupling between the fiber optics and the skin was consistently the same for all of the eight source fibers. This condition is extremely important in multi-distance measurements, and results in more reliable and reproducible measurements. The movements (jarring during the running exercise) of the subject did not cause any spikes or artifacts in the measured traces. As a result, we never had reason to discard a data set, which was sometimes done with the previous prototype because of non uniform optical couplings and/or movement artifacts.

The short on-period of each laser diode (20 ms) allowed us to complete an acquisition cycle (80 ms per wavelength) in a time much shorter than the heart beat, respiratory periods, and the stride period. To quantify the reduction in the measurement noise resulting from this new procedure, we have also acquired data with a 1250 Hz cross-correlation frequency (80 ms per laser diode, 320 ms per wavelength). Figure 5 shows the lower noise associated with shorter time per cycle. The data is acquired on the calf during a running exercise.

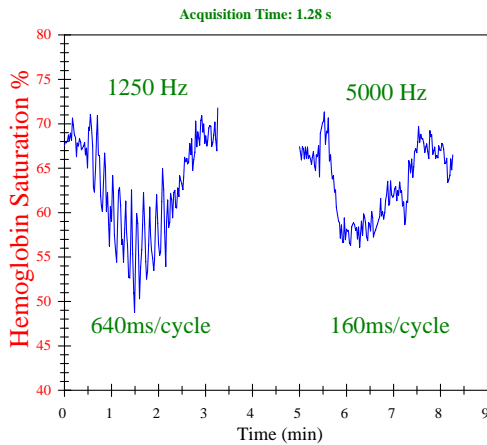

Fig. 5. Comparison between hemoglobin saturation traces collected with cross-correlation frequencies of 1250 Hz and 5000 Hz. The acquisition time is the same: 1.28 s. These measurements were taken on the calf of a volunteer during a running exercise (which caused the decrease in the hemoglobin saturation). The lower noise in the trace at 5000 Hz results from the shorter on-time of each light source (20 ms @ 5000 Hz, versus 80 ms @ 1250 Hz). Physiological rhythms on a time scale of the order of one second are not a concern at the higher cross-correlation frequency.

6. CONCLUSION

We have presented a second generation frequency-domain tissue oximeter which operates in the near-infrared. In its design, we have kept the basic principle of acquiring data at multiple source-detector separations by multiplexing multiple light sources. This approach was implemented in a first generation prototype which has given promising results both on phantoms and *in vivo*. The technical improvements achieved with the new design result in a more practical, reliable, reproducible, and versatile unit, which is more appropriate for clinical trials. In conducting the *in vivo* measurements presented in this paper, we have verified the improvement in the design and engineering of the instrument. We have started clinical trials where the technical and practical effectiveness of the new prototype has been confirmed. We conclude by observing that the data collected by this tissue oximeter also include continuous wave (CW) data (i.e. the dc intensity), and single distance data. This means that we are able to compare the effectiveness of cw and single-distance methods with respect to our frequency-domain multi-distance approach. We are currently working on this topic.

ACKNOWLEDGEMENTS

This work was supported by National Institute of Health (NIH) grants RR03155, CA57032, and by Whitaker-NIH grant RR10966. ISS was supported by grant RR0827 from the National Center for Research Resources of the NIH.

REFERENCES

1. S. Fantini, M. A. Franceschini, J. S. Maier, S. A. Walker, B. Barbieri, and E. Gratton, "Frequency-Domain Multichannel Optical Detector for non-Invasive Tissue Spectroscopy and Oximetry," *Opt. Eng.* **34**, pp. 32-42, 1995.
2. S. Fantini, M. A. Franceschini, and E. Gratton, "Semi-Infinite-Geometry Boundary Problem for Light Migration in Highly Scattering Media: a Frequency-Domain Study in the Diffusion Approximation," *J. Opt. Soc. Am. B* **11**, pp. 2128-2138, 1994.
3. T. J. Farrel, M. S. Patterson, and B. Wilson, "A Diffusion Theory Model of Spatially Resolved, Steady-State Diffuse Reflectance for the Noninvasive Determination of Tissue Optical Properties *in vivo*," *Med. Phys.* **19**, 879-888 (1992).
4. J. T. Bruulsema, M. Essenpreis, L. Heinemann, J. E. Hayward, M. Berger, F. A. Gries, T. Koschinsky, J. Sandahl-Christiansen, H. Orskov, T. J. Farrel, M. S. Patterson, D. Bocker, "Detection of Changes in Blood Glucose Concentration *in vivo* with Spatially Resolved Diffuse Reflectance", *OSA Trends in Optics and Photonics on Biomedical Optical Spectroscopy and Diagnostics*, E. Sevick-Muraca and D. Benaron, eds. (Optical Society of America, Washington, DC 1996), Vol. 3, pp. 2-6.
5. S. J. Madsen, E. R. Anderson, R. C. Haskell, and B. J. Tromberg, "Portable, high-bandwidth frequency-domain photon migration instrument for tissue spectroscopy", *Opt. Lett.* **19**, 1934-1936 (1994).
6. M. Miwa, Y. Ueda and B. Chance, "Development of Time Resolved Spectroscopy System for Quantitative Non-Invasive Tissue Measurement," *Proc. SPIE*, **2389**, 142-149 (1995).
7. M. A. Franceschini, S. Fantini, A. E. Cerussi, B. Barbieri, B. Chance, and E. Gratton, "Quantitative Spectroscopic Determination of Hemoglobin Concentration and Saturation in a Turbid Medium: Analysis of the Effect of Water Absorption," *J. Biomed. Opt.*, *in press*.
8. M. A. Franceschini, S. Fantini, A. E. Cerussi, B. Barbieri, B. Chance, and E. Gratton, "The Effect of Water in the Quantitation of Hemoglobin Concentration in a Tissue-Like Phantom by Near-Infrared Spectroscopy," *OSA Trends in Optics and Photonics on Biomedical Optical Spectroscopy and Diagnostics*, E. Sevick-Muraca and D. Benaron, eds. (Optical Society of America, Washington, DC 1996), Vol. 3, pp. 126-130.
9. J. S. Maier, S. A. Walker, S. Fantini, M. A. Franceschini, and E. Gratton, "Possible Correlation between Blood Glucose Concentration and the Reduced Scattering Coefficient of Tissues in the Near Infrared," *Opt. Lett.* **19**, 2062-2064 (1994).
10. R. A. De Blasi, S. Fantini, M. A. Franceschini, M. Ferrari, and E. Gratton, "Cerebral and Muscle Oxygen Saturation Measurement by Frequency-Domain Near-Infra-red Spectrometer," *Med. Biol. Eng. Comput.* **33**, 228-230 (1995).
11. J. S. Maier, B. Barbieri, A. Chervu, I. Chervu, S. Fantini, M. A. Franceschini, M. Levi W. W. Mantulin, A. Rosenberg, S. A. Walker, and E. Gratton, "*In Vivo* Study of Human Tissues with a Portable Near-Infrared Tissue Spectrometer," *Proc. SPIE* **2387**, 240-248 (1995).
12. V. Quaresima, A. Pizzi, R. A. De Blasi, A. Ferrari, M. De Angelis, and M. Ferrari, "Quadriceps Oxygenation Changes During Walking and Running on a Treadmill," *Proc. SPIE* **2387**, 249-256 (1995).
13. M. Ferrari, R. A. De Blasi, S. Fantini, M. A. Franceschini, B. Barbieri, V. Quaresima, and E. Gratton, "Cerebral and Muscle Oxygen Saturation Measurement by a Frequency-Domain Near-Infrared Spectroscopic Technique," *Proc. SPIE* **2389**, 868-874 (1995).