

# QUANTITATIVE SPECTROSCOPIC DETERMINATION OF HEMOGLOBIN CONCENTRATION AND SATURATION IN A TURBID MEDIUM: ANALYSIS OF THE EFFECT OF WATER ABSORPTION

Maria Angela Franceschini,<sup>†</sup> Sergio Fantini,<sup>†</sup> Albert Cerussi,<sup>†</sup> Beniamino Barbieri,<sup>\*</sup> Britton Chance,<sup>\*\*</sup> and Enrico Gratton<sup>†</sup>

<sup>†</sup>University of Illinois at Urbana Champaign, Department of Physics, Laboratory for Fluorescence Dynamics, 1110 West Green Street, Urbana, Illinois 61801; <sup>\*</sup>ISS Incorporated, 2604 North Mattis Avenue, Champaign, Illinois, 61821; <sup>\*\*</sup>University of Pennsylvania, Department of Biophysics/Biochemistry, D501 Richards Building, 37th & Hamilton Walk, Philadelphia, Pennsylvania 19104-6089

(Paper JBO/NIR-04 received Apr. 29, 1996; revised manuscript received Nov. 20, 1996; accepted for publication Dec. 26, 1996.)

## ABSTRACT

The contribution of water to the quantitative determination of hemoglobin concentration and saturation by near-infrared spectroscopy in turbid media was investigated. The study consisted of *in vitro* measurements of an aqueous suspension containing Liposyn, bovine blood, and yeast buffered at pH 7.2. The optical coefficients of the medium ( $\mu_a \sim 0.03$  to  $0.08 \text{ cm}^{-1}$ ,  $\mu'_s \sim 6 \text{ cm}^{-1}$  at wavelengths of 715 and 825 nm) were similar to those of biological tissue in the near-infrared, and the hemoglobin concentration was about  $23 \mu\text{M}$ . It was possible to reversibly saturate and desaturate hemoglobin in the full range of 0 to 100% by flowing either oxygen or nitrogen through the suspension. In these experimental conditions, water absorption must be taken into account to obtain accurate oxyhemoglobin concentrations and low hemoglobin saturation values. By contrast, the water correction has a small effect on the determination of deoxyhemoglobin concentration and high hemoglobin saturation values. By extrapolating the result to physiological conditions, where water content is lower and hemoglobin content is higher than in the experimental conditions, it was concluded that water absorption should have a smaller effect on the determination of hemoglobin concentrations and saturation in tissues at the wavelengths used in this study. In particular, for hemoglobin concentrations larger than  $100 \mu\text{M}$ , the water correction is less than 5% at saturation values higher than 50%. © 1997 Society of Photo-Optical Instrumentation Engineers.

**Keywords** near infrared spectroscopy; hemoglobin saturation; strongly scattering media; noninvasive tissue oximetry.

## 1 INTRODUCTION

The quantitative measurement of hemoglobin oxygenation in tissues is fundamental to prevent hypoxic or hyperoxic conditions in ill patients. A non-invasive, accurate, continuous, and *in situ* monitor of hemoglobin oxygenation is one of the goals of near-infrared spectroscopy. Optical measurements of hemoglobin oxygenation rely on the difference between the absorption spectra of oxy- and deoxy-hemoglobin ( $\text{HbO}_2$  and Hb, respectively) in the near-infrared. In blood-perfused tissues, hemoglobin is the major absorber in the near infrared (700 to 900 nm). Therefore, a measurement of light attenuation at two different wavelengths can be related to the hemoglobin saturation of the investigated tissue.

The first optical oximeters were developed in the 1940s.<sup>1</sup> These instruments were based on the Beer-Lambert law, and required a calibration measurement in the absence of blood to correct for light scattering in the tissue. A different approach to measuring arterial oxygen saturation ( $\text{SaO}_2$ ) using optical methods was proposed by Aoyagi et al.<sup>2</sup> and by Yoshiya et al.<sup>3</sup> The changes in arterial blood volume associated with cardiac contractions cause changes in absorbance. The differences between the peak and the baseline absorbances at two wavelengths are ratioed. This ratio can be empirically correlated with the absolute value of  $\text{SaO}_2$  by means of a large population statistical study.

The pulse oximeter, which is based on this approach, is now largely used in hospitals as a moni-

Address all correspondence to Maria Angela Franceschini. E-mail: mari@fd.physics.uiuc.edu

toring medical device.<sup>4</sup> It has, however, limitations and inaccuracies in the absolute determination of  $\text{SaO}_2$  which prevent its use in some medical applications. Near infrared instruments that employ continuous wave (CW) light were developed in the late 1980s and early 1990s. Some of these instruments obtain the relative changes in hemoglobin saturation in tissues by combining the measured light intensity at two different wavelengths.<sup>5,6</sup> Others quantitatively determine the hemoglobin saturation and changes in hemoglobin concentration by assuming a constant value for either the average optical path length<sup>7,8</sup> or the reduced scattering coefficient.<sup>9</sup> The path length is determined from measurements on a population of healthy people. Even if promising clinical results are achieved with these instruments<sup>9,10</sup> some criticisms about the basic assumption of constant path length have been raised.<sup>11,12</sup>

The introduction of time-resolved spectroscopy, in conjunction with a theoretical model, the diffusion theory, which satisfactorily describes light propagation in biological tissues,<sup>13</sup> has recently led to the development of tissue oximeters operating in both the frequency domain<sup>14</sup> and the time domain.<sup>15</sup> These instruments measure the absorption ( $\mu_a$ ) and the reduced scattering ( $\mu'_s$ ) coefficients of tissue without making assumptions about the optical path length. As a result, these instruments provide an absolute measurement of the optical coefficients of tissue. To translate the values of the absorption coefficients of tissues into hemoglobin concentration and hemoglobin saturation, one typically assumes that the absorption of near infrared light in tissues is solely due to oxy- and deoxy-hemoglobin. Essenpreis et al. have made an attempt to include the effect of the absorption of water and cytochrome  $aa_3$  in a fit of a time-domain measurement, which was partially successful in quantifying hemoglobin saturation values.<sup>16</sup>

In this paper we investigate the effect of water on the absolute determination of the concentrations of oxy- and deoxyhemoglobin by optical methods. We compare theoretical predictions with the results of an *in vitro* experiment on a Liposyn aqueous suspension containing a known concentration of bovine blood. In this experiment, we were able to reversibly change the oxygenation status of hemoglobin in the full range of 0 to 100% by flowing either oxygen or nitrogen through the medium. While our *in vitro* experiments exaggerate the effect of water in tissues, they provide a good test for predicting the extent of the water contribution in physiological conditions.

## 2 MATERIALS AND METHODS

The turbid suspension was made of bovine blood (93 ml), 7.2 pH buffer (9 liters), Liposyn 20% (231

ml), and yeast (47 g, Fleischman<sup>®</sup>). This suspension was placed in a rectangular container 32 cm long  $\times$  27 cm wide  $\times$  12 cm deep, and the total volume of the liquid was about 9.4 liters. The pH buffer was an aqueous solution of dibasic sodium phosphate (13 g/liter) and hydrochloric acid. We verified that the buffered pH value of 7.2 was not changed by adding blood. The concentration of 0.5% solid content of Liposyn 20% was chosen to yield a reduced scattering coefficient of about 5 to 6  $\text{cm}^{-1}$  in the near infrared spectral region. The blood concentration (1% by volume) was chosen to yield absorption coefficients smaller than 0.1  $\text{cm}^{-1}$  (to base  $e$ ) to obtain a high level of detected intensity. A hemoglobin concentration of 23  $\mu\text{M}$  was estimated by taking its concentration in blood equal to 15 g/100 ml, and its molecular weight equal to 64,000 g/mole. The water content of the suspension was 99% by volume. The suspension was enclosed in a gas-impermeable sealed bag, and a constant flux of either oxygen or nitrogen was maintained through the suspension via a tube located in the bottom part of the container. In this way a 100% oxygen or 100% nitrogen atmosphere was attainable in the sealed bag. Consequently, the hemoglobin saturation could be varied (reversibly) from 100 to 0%.

We used a frequency-domain spectrometer to measure the optical properties of the suspension. The principle of operation is described elsewhere.<sup>17</sup> The light sources of the frequency-domain spectrometer were two light-emitting diodes (LEDs) peaked at  $\lambda_1=715$  nm (HP HEMT-6000) and  $\lambda_2=825$  nm (Motorola MFOE1203), and having spectral bandwidths of  $\Delta\lambda_1=30$  nm and  $\Delta\lambda_2=50$  nm, respectively. They were positioned 3 cm below the surface of the suspension. A detector fiber (3 mm in diameter), movable by a step motor controlled by a computer, was also positioned 3 cm below the surface of the liquid. In the range of optical coefficients considered here, this configuration of sources and detector satisfies the boundary conditions of the infinite medium geometry. Measurements with the frequency-domain spectrometer were done only in 100 and 0% hemoglobin saturation conditions. The acquisition time for each wavelength was about 30 s, allowing for an accuracy in the determination of  $\mu_a$  and  $\mu'_s$  of about 3%.

An oxygen electrode (ORION, model 97-08) was used to measure the partial pressure of oxygen ( $\text{pO}_2$ ) in the suspension. The setup also included an OMNIA near infrared tissue oximeter (ISS, Champaign, Illinois), whose readings (not recorded in this paper) agreed with those of the frequency-domain spectrometer.<sup>18</sup> The experimental apparatus is shown in Figure 1, which also shows the stirrer (5  $\times$  1 cm stirring cylinder,  $\approx$ 200 rpm) that was used to prevent hemoglobin and suspended particles from settling.

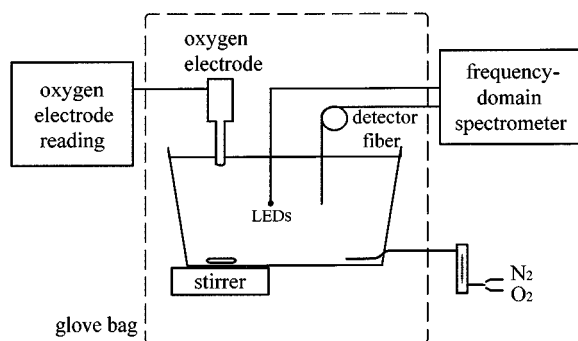

**Fig. 1** Experimental setup. The sample is a turbid suspension having optical properties similar to those of tissue ( $\mu_a \sim 0.05 \text{ cm}^{-1}$ ,  $\mu'_s \sim 6 \text{ cm}^{-1}$ ). The suspension has a hemoglobin concentration of about  $23 \mu\text{M}$ . A magnetic stirring bar prevents hemoglobin and scattering particles (from Liposyn 20%) from settling. The whole suspension is enclosed in a gas-impermeable glove bag, and by flowing either oxygen ( $\text{O}_2$ ) or nitrogen ( $\text{N}_2$ ) through the suspension we can control the atmosphere inside the glove bag. The optical readings are obtained by an accurate frequency-domain spectrometer for turbid media (light sources: LEDs; light collection: optical fiber) which performs multidistance data acquisition in an infinite geometry. During the experiment, we also monitored the dissolved oxygen concentration with a commercial oxygen electrode (ORION, model 97-08).

### 3 RESULTS

The measurements of  $\mu_a$  and  $\mu'_s$  were taken at three different values of  $\text{pO}_2$  in the suspension:

1. The initial measurement was performed at 150 mm Hg  $\text{pO}_2$ . This  $\text{pO}_2$  in air is sufficient to completely saturate hemoglobin.<sup>19</sup>
2. A flow of oxygen was started and then maintained for 80 min. The second measurement was then performed at 600 mm Hg  $\text{pO}_2$  as measured by the oxygen electrode.
3. We then stopped the oxygen flow, added the yeast to the suspension, and started a flow of nitrogen gas. After about 100 min, we performed the measurement at 0 mm Hg  $\text{pO}_2$  as measured by the oxygen electrode.

We later verified that we could reproduce measurement 2 after replenishing the oxygen in the suspension.

Table 1 gives a summary of the experimental data for each measurement. The first column gives the reading of  $\text{pO}_2$  provided by the oxygen electrode in the suspension. The next four columns give the absorption and reduced scattering coefficients of the suspension measured by the frequency-domain spectrometer at both  $\lambda_1$  and  $\lambda_2$ . The oxygen saturation ( $Y$ ) reported in the last column is obtained by assuming that oxy- and deoxyhemoglobin are the only absorbers in the suspension. While we obtain  $Y=100\%$  in the oxygen atmosphere as expected,<sup>19</sup> we obtain  $Y=40\%$  instead of 0% when the  $\text{pO}_2$  is zero in the suspension. In the next section, we show that the erroneous result is caused by neglecting water absorption.

### 4 DISCUSSION

The relationship between the measured absorption coefficient at wavelength  $\lambda$  and the concentrations of chromophores in the medium is given by:

$$\mu_a^\lambda = \sum_i \epsilon_i^\lambda [C_i], \quad (1)$$

where  $\epsilon_i^\lambda$  is the extinction coefficient at  $\lambda$  of the chromophore  $C_i$ , whose concentration is  $[C_i]$ . In tissues, the summation is usually limited to the oxy- and deoxyhemoglobin species.<sup>14,15,20</sup> Using this simplified approach, we correctly measure 100% saturation in the oxygen atmosphere, but we do not obtain the expected saturation value of 0% in the nitrogen atmosphere (see Table 1). The main constituent by volume in our suspension is water, and its contribution to Eq. (1) should be considered. Since our suspension had a water content of nearly 100%, we included an additional term in Eq. (1) given by  $\mu_{a_{\text{H}_2\text{O}}}^\lambda$ . The system of two Eqs. (1) for  $\mu_a^{\lambda_1}$  and  $\mu_a^{\lambda_2}$  yields the following solution for  $[\text{HbO}_2]$  and  $[\text{Hb}]$ :

**Table 1** Optical coefficients ( $\mu_a$  and  $\mu'_s$ ) and uncorrected-for-water hemoglobin saturation ( $Y^*$ ), as measured in the three stages of the experiment.

$\text{pO}_2$ (mm Hg)	$\lambda_1=715 \text{ nm}$		$\lambda_2=825 \text{ nm}$		$Y^*$ (%) neglecting $\text{H}_2\text{O}$ absorption
	$\mu_a \text{ (cm}^{-1}\text{)}$	$\mu'_s \text{ (cm}^{-1}\text{)}$	$\mu_a \text{ (cm}^{-1}\text{)}$	$\mu'_s \text{ (cm}^{-1}\text{)}$	
150	$0.032 \pm 0.001$	$6.1 \pm 0.2$	$0.069 \pm 0.002$	$5.0 \pm 0.1$	$100 \pm 2$
600	$0.030 \pm 0.001$	$5.8 \pm 0.2$	$0.068 \pm 0.002$	$4.9 \pm 0.1$	$102 \pm 2$
0	$0.084 \pm 0.003$	$5.7 \pm 0.2$	$0.066 \pm 0.002$	$5.0 \pm 0.1$	$40 \pm 3$

Note: The first column shows the  $\text{pO}_2$  in mm Hg inside the suspension measured with the oxygen electrode. The next four columns give the absorption and reduced scattering coefficients of the suspension measured by the frequency-domain spectrometer at the given LED peak wavelength. The last column gives the calculated oxygen saturation in percent assuming that only  $[\text{HbO}_2]$  and  $[\text{Hb}]$  act as absorbers. Notice that we properly obtain 100% in the high  $\text{pO}_2$  case, but we obtain 40% instead of 0% when the  $\text{pO}_2$  is zero.

**Table 2** Calculated concentrations of oxy- and deoxyhemoglobin inside the suspension, using the measured values of absorption coefficients reported in Table I. The estimated water-corrected and uncorrected-for-water values are given.

pO <sub>2</sub> (mm Hg)	[HbO <sub>2</sub> ] (μM)			[Hb] (μM)		
	Estimated	H <sub>2</sub> O-corrected	Non-H <sub>2</sub> O-corrected	Estimated	H <sub>2</sub> O-corrected	Non-H <sub>2</sub> O-corrected
150	23	18±1	30±1	0	0.4±0.5	0.1±0.5
600	23	18±1	31±1	0	-0.4±0.5	-0.7±0.5
0	0	1±1	13±1	23	20 ±1	20 ±1

$$[\text{HbO}_2] = \frac{\mu_{a_{\text{measured}}}^{\lambda_1} \epsilon_{\text{Hb}}^{\lambda_2} - \mu_{a_{\text{measured}}}^{\lambda_2} \epsilon_{\text{Hb}}^{\lambda_1}}{\epsilon} - \frac{\mu_{a_{\text{H}_2\text{O}}}^{\lambda_1} \epsilon_{\text{Hb}}^{\lambda_2} - \mu_{a_{\text{H}_2\text{O}}}^{\lambda_2} \epsilon_{\text{Hb}}^{\lambda_1}}{\epsilon} = [\text{HbO}_2]^* - K_{\text{HbO}_2}(\lambda_1, \lambda_2), \quad (2)$$

$$[\text{Hb}] = \frac{\mu_{a_{\text{measured}}}^{\lambda_2} \epsilon_{\text{HbO}_2}^{\lambda_1} - \mu_{a_{\text{measured}}}^{\lambda_1} \epsilon_{\text{HbO}_2}^{\lambda_2}}{\epsilon} - \frac{\mu_{a_{\text{H}_2\text{O}}}^{\lambda_2} \epsilon_{\text{HbO}_2}^{\lambda_1} - \mu_{a_{\text{H}_2\text{O}}}^{\lambda_1} \epsilon_{\text{HbO}_2}^{\lambda_2}}{\epsilon} = [\text{Hb}]^* - K_{\text{Hb}}(\lambda_1, \lambda_2), \quad (3)$$

where  $\epsilon = \epsilon_{\text{HbO}_2}^{\lambda_1} \epsilon_{\text{Hb}}^{\lambda_2} - \epsilon_{\text{HbO}_2}^{\lambda_2} \epsilon_{\text{Hb}}^{\lambda_1}$ ,  $[\text{HbO}_2]^*$  and  $[\text{Hb}]^*$  are the values of oxy- and deoxyhemoglobin concentrations obtained if hemoglobin is assumed to be the only absorber, and  $K_{\text{HbO}_2}(\lambda_1, \lambda_2)$  and  $K_{\text{Hb}}(\lambda_1, \lambda_2)$  are the water-correction terms. Table 2 presents the estimated, water-corrected, and water-uncorrected values of the hemoglobin concentrations  $[\text{HbO}_2]$  and  $[\text{Hb}]$ . We used the following parameters for the calculations:  $\mu_{a_{\text{H}_2\text{O}}}^{\lambda_1} = 0.012 \text{ cm}^{-1}$ ,  $\mu_{a_{\text{H}_2\text{O}}}^{\lambda_2} = 0.028 \text{ cm}^{-1}$ ,<sup>21</sup>  $\epsilon_{\text{HbO}_2}^{\lambda_1} = 1.045 \text{ (mM}^{-1} \times \text{cm}^{-1})$ ,  $\epsilon_{\text{HbO}_2}^{\lambda_2} = 2.263 \text{ (mM}^{-1} \times \text{cm}^{-1})$ ,  $\epsilon_{\text{Hb}}^{\lambda_1} = 3.484 \text{ (mM}^{-1} \times \text{cm}^{-1})$ ,  $\epsilon_{\text{Hb}}^{\lambda_2} = 1.794 \text{ (mM}^{-1} \times \text{cm}^{-1})$ ,<sup>22</sup> (all absorption coefficients here are to base  $e$ ). For these parameters,  $K_{\text{HbO}_2} = 12.5 \text{ } \mu\text{M}$ , and  $K_{\text{Hb}} = -0.29 \text{ } \mu\text{M}$ .  $K_{\text{HbO}_2}$  is of the same order of magnitude as the concentration of hemoglobin present in our suspension. This explains the large discrepancy between  $[\text{HbO}_2]$  and  $[\text{HbO}_2]^*$ . Instead,  $K_{\text{Hb}}$  is negligible compared with the concentration of hemoglobin in the suspension and hence it does not significantly affect the determination of  $[\text{Hb}]$ . Figure 2 shows the values of  $K_{\text{HbO}_2}$  and  $K_{\text{Hb}}$  as a function of  $\lambda_1$  for three different values of  $\lambda_2$  (800, 825, and 850 nm). Figure 2 shows that water can have different effects on the determination of hemoglobin concentration for different pairs of wavelengths employed.

By summing the concentrations of oxy- and deoxyhemoglobin, we obtain the total hemoglobin content ( $THC$ ). Table 3 shows the estimated, water-corrected, and water-uncorrected values of  $THC$ . The quantitative result for  $THC$  after water correction is in good agreement with the estimated value. Table 3 also shows the actual, water-corrected, and water-uncorrected values of hemoglobin saturation ( $Y$ ). The effect of water correction is negligible in the high saturation limit, but it becomes increasingly important at lower saturation values.

The explanation for the different results in the oxygenated and deoxygenated states is the following. In the high saturation limit ( $[\text{HbO}_2] \approx THC$ ,  $[\text{Hb}] \approx 0$ ) we have:

$$Y^* = \frac{[\text{HbO}_2]^*}{[\text{HbO}_2]^* + [\text{Hb}]^*} \times 100\% = \frac{[\text{HbO}_2] + K_{\text{HbO}_2}}{[\text{HbO}_2] + K_{\text{HbO}_2} + [\text{Hb}] + K_{\text{Hb}}} \times 100\%$$

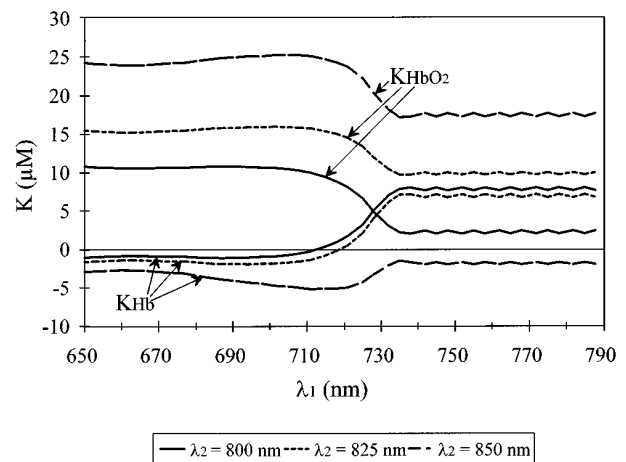
**Fig. 2** Water correction terms for oxyhemoglobin ( $K_{\text{HbO}_2}$ ) and for deoxyhemoglobin ( $K_{\text{Hb}}$ ) as a function of  $\lambda_1$  [for the definitions of  $K_{\text{HbO}_2}$  and  $K_{\text{Hb}}$  see Eqs. (2) and (3)]. The water correction terms have been calculated for three values of  $\lambda_2$ , namely 800, 825, and 850 nm.

**Table 3** Calculated values of total hemoglobin content (*THC*) and hemoglobin saturation (*Y*) inside the suspension, using the measured values of absorption coefficients reported in Table I.

pO <sub>2</sub> (mm Hg)	<i>THC</i> (μM)			<i>Y</i> (%)		
	Estimated	H <sub>2</sub> O-corrected	Non-H <sub>2</sub> O-corrected	Actual	H <sub>2</sub> O-corrected	Non-H <sub>2</sub> O-corrected
150	23	18±1	30±1	100	98±3	100±2
600	23	18±1	31±1	100	102±3	102±2
0	23	21±2	34±2	0	5±6	40±3

$$\approx \frac{THC + K_{HbO_2}}{THC + K_{HbO_2} + K_{Hb}} \times 100\%, \quad (4)$$

where  $Y^*$  is the uncorrected-for-water value. If  $K_{Hb} \ll THC$ , then  $Y^* \approx 100\%$  independently of the value of  $K_{HbO_2}$ . In our experimental conditions  $K_{Hb}$  ( $-0.29 \mu M$ ) was actually much smaller than  $THC$  ( $23 \mu M$ ) and we recovered a value of  $Y^* \approx 100\%$  in full saturation. In the low saturation limit ( $[HbO_2] \approx 0$ ,  $[Hb] \approx THC$ ) we have:

$$\begin{aligned} Y^* &= \frac{[HbO_2]^*}{[HbO_2]^* + [Hb]^*} \times 100\% \\ &= \frac{[HbO_2] + K_{HbO_2}}{[HbO_2] + K_{HbO_2} + [Hb] + K_{Hb}} \times 100\% \\ &\approx \frac{K_{HbO_2}}{K_{HbO_2} + THC + K_{Hb}} \times 100\%. \end{aligned} \quad (5)$$

If  $K_{Hb} \ll THC$  and  $K_{HbO_2} \ll THC$ , then  $Y^* \approx 0\%$ . In our experimental conditions  $K_{HbO_2}$  ( $12.5 \mu M$ ) was not much smaller than  $THC$  ( $19 \mu M$ ) and we recovered a value of  $Y^* \approx 40\%$  at full desaturation.

We have calculated the dependence of the hemoglobin saturation uncorrected for water ( $Y^*$ ) on the hemoglobin concentration for the pair of wavelengths employed in this study ( $\lambda_1=715$  nm and  $\lambda_2=825$  nm). Figure 3 shows  $Y^*$  versus  $THC$  for different values of  $Y$  (11 curves for  $Y$  ranging from 0 to 100% at increments of 10%). For the hemoglobin concentration employed in our *in vitro* experiment, the water correction is important. However, for the hemoglobin concentration in tissues (55 to 220  $\mu M$ ),<sup>23-29</sup> this correction would be relevant (greater than 5%) only in the low concentration limit and at low saturation values. The water correction can be quantified in a given condition by inspection of Figure 3. For example, the water correction to  $Y$  is less than 5% at hemoglobin concentrations larger than 100  $\mu M$  and for saturation values higher than 50%. This implies that hemoglobin saturation measurements of the OMNIA tissue oximeter (as well as other optical oximeters based on a quantitative determination of  $\mu_a$ ) operating at  $\lambda_1=715$  nm and

$\lambda_2=825$  nm will be only slightly affected by the effect of water absorption in many physiological conditions.

To perform the water correction, which we have actually implemented in the software of the OMNIA oximeter, one must estimate the water concentration in the tissue. This concentration varies over a wide range of values. For instance, it can assume values in the ranges of 75 to 80% in the brain, 66 to 82% in the skeletal muscle, 52 to 78% in the skin, and 6 to 36% in fatty tissue.<sup>30</sup> Furthermore, the water concentration may change during a measurement. The relevance of our conclusion that the water correction, even when not negligible, should not be a dominant factor, is that a bad estimate of water concentration will not cause significant errors in the determination of hemoglobin concentration and saturation.

## 5 CONCLUSIONS

Near infrared spectroscopy has the potential of determining quantitative values of hemoglobin concentration and saturation in blood-perfused tissues.

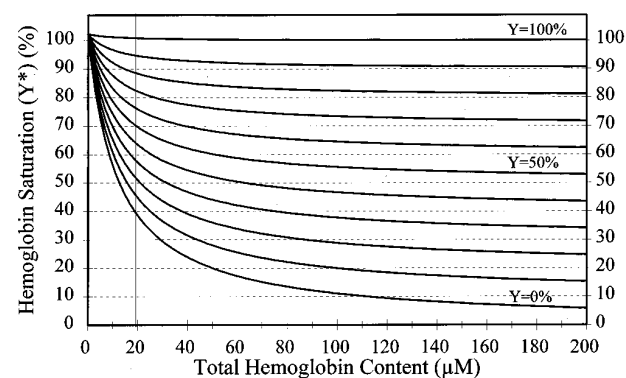

**Fig. 3** Calculated values of hemoglobin saturation without water correction for 11 values of actual saturation (from 0 to 100% at increments of 10%) as a function of total hemoglobin content ( $THC$ ). In this plot, we have considered the same wavelengths employed in our experiment, i.e.,  $\lambda_1=715$  nm and  $\lambda_2=825$  nm. In these conditions, the water correction is relevant at low values of hemoglobin saturation and concentration. The vertical line indicates the value of  $THC$  measured in our experiment.

This potential has already been exploited by quantitative oximeters in the frequency domain<sup>14</sup> and the time domain.<sup>15</sup> However, these instruments work under the assumption that hemoglobin is the only absorber in the near infrared. While this is a reasonable first-step approximation, it might lead to systematic errors. In this study we investigated the effect of a third absorber, namely water, on the quantitative determination of hemoglobin concentration and saturation in turbid media. Our results show that the effect of water depends on the total hemoglobin content and on the pair of wavelengths used by the optical oximeter. For the total hemoglobin content (23  $\mu\text{M}$ ) and wavelengths (715 and 825 nm) employed in this study, the water correction has little effect on the determination of Hb concentration and of high saturation values. On the other hand, the water correction is relevant in the determination of HbO<sub>2</sub> concentration and low saturation values. Extrapolating our result to physiological conditions which are characterized by lower water content and a higher hemoglobin content, we conclude that water absorption should have a smaller effect on the determination of hemoglobin concentration and saturation in tissues. This effect is quantified by Eqs. (2) and (3), and by Figure 3. However, under physiological conditions, background absorption could be due to other chromophores besides water. Furthermore, the water absorption in tissues could be different than that of bulk water due to changes in the spectrum of bound water. Intrinsic tissue inhomogeneities may also play a role in the quantitative determination of optical parameters.

### Acknowledgments

The Laboratory for Fluorescence Dynamics is supported by the National Institutes of Health (NIH) Grant RR03155 and by the University of Illinois at Urbana-Champaign. This research is also supported by NIH Grant CA57032 and by a joint Whitaker-NIH Grant RR10966.

### REFERENCES

- G. A. Millikan, "The oximeter, an instrument for measuring continuously the oxygen saturation of arterial blood in man," *Rev. Sci. Instr.* **13**, 434-444 (1942).
- T. Aoyagi, M. Kishi, K. Yamaguchi, and S. Watanabe, "Improvement of the earpiece oximeter," *Abst. Jpn. Soc. Med. Electronics Biol. Eng.* 90-91 (1974).
- I. Yoshiya, Y. Shimada, and K. Tanaka, "Spectrophotometric monitoring of arterial oxygen saturation in the fingertip," *Med. Biol. Eng. Comput.* **18**, 27-32 (1980).
- Y. Mendelson, "Pulse oximetry: theory and applications for noninvasive monitoring," *Clin. Chem.* **38**, 1601-1607 (1992).
- K. Sahlin, "Non-invasive measurements of O<sub>2</sub> availability in human skeletal muscle with near-infrared spectroscopy," *Int. J. Sports Med.* **13**, 157-160 (1992).
- L. Rovati, P. Lago, R. Colombo, U. Corrà, F. De Vito, and M. Corti, "A simple NIR instrument for diagnostic purposes," *Proc. SPIE* **2324**, 109-116 (1995).
- M. Cope and D. T. Delpy, "System for long-term measurement of cerebral blood and tissue oxygenation in newborn infants by near infrared transillumination," *Med. Biol. Eng. Comput.* **26**, 289-294 (1988).
- P. W. McCormick, M. Stewart, M. G. Goetting, M. Dujovny, G. Lewis, and J. I. Ausman, "Noninvasive cerebral optical spectroscopy for monitoring cerebral oxygen delivery and hemodynamics," *Clinical Care Med.* **19**, 89-97 (1991).
- W. J. Levy, S. Levin, and B. Chance, "Near-infrared measurement of cerebral oxygenation: correlation with electroencephalographic ischemia during ventricular fibrillation," *Anesthesiology* **83**, 738-746 (1995).
- A. D. Edwards, J. S. Wyatt, C. Richardson, A. Potter, M. Cope, D. T. Delpy, and E. O. R. Reynolds, "Effects of indomethacin on cerebral haemodynamics in very preterm infants," *Lancet* **335**, 1491-1495 (1990).
- M. Ferrari, Q. Wei, L. Carraresi, R. de Blasi, and G. Zaccanti, "Time-resolved spectroscopy of the human forearm," *J. Photochem. Photobiol. B* **16**, 141-153 (1992).
- D. A. Benaron, J. P. Van Houten, W. Cheong, E. L. Kermit, and R. A. King, "Early clinical results of time-of-flight optical tomography in a neonatal intensive care unit," *Proc. SPIE* **2389**, 582-596 (1995).
- M. S. Patterson, B. Chance, and B. C. Wilson, "Time resolved reflectance and transmittance for the non-invasive measurement of optical properties," *Appl. Opt.* **28**, 2331-2336 (1989).
- S. Fantini, M. A. Franceschini, J. S. Maier, S. A. Walker, B. Barbieri, and E. Gratton, "Frequency-domain multichannel optical detector for non-invasive tissue spectroscopy and oximetry," *Opt. Eng.* **34**, 32-42 (1995).
- M. Miwa, Y. Ueda, and B. Chance, "Development of time resolved spectroscopy system for quantitative non-invasive tissue measurement," *Proc. SPIE* **2389**, 142-149 (1995).
- M. Essenpreis, C. E. Elwell, M. Cope, P. van der Zee, S. R. Arridge, and D. T. Delpy, "Spectral dependence of temporal point spread functions in human tissue," *Appl. Opt.* **32**, 418-425 (1993).
- S. Fantini, M. A. Franceschini, J. B. Fishkin, B. Barbieri, and E. Gratton, "Quantitative determination of the absorption spectra of chromophores in strongly scattering media: a light-emitting-diode based technique," *Appl. Opt.* **33**, 5204-5213 (1994).
- M. A. Franceschini, S. Fantini, A. Cerussi, B. Barbieri, B. Chance, and E. Gratton, "The effect of water in the quantitation of hemoglobin concentration in a tissue-like phantom by near-infrared spectroscopy," in *OSA Trends in Optics and Photonics on Biomedical Optical Spectroscopy and Diagnostics*, Vol. 3, pp. 126-130, E. Sevick-Muraca and D. Benaron, Eds., Optical Society of America, Washington, DC (1996).
- C. R. Cantor and P. R. Schimmel, *Biophysical Chemistry*, Part III, pp. 963-964, W. H. Freeman, New York (1969).
- E. M. Sevick, B. Chance, J. Leigh, S. Nioka, and M. Maris, "Quantitation of time- and frequency-resolved optical spectra for the determination of tissue oxygenation," *Anal. Biochem.* **195**, 330-351 (1991).
- G. M. Hale and M. R. Querry, "Optical constants of water in the 200 nm to 200  $\mu\text{m}$  wavelength region," *Appl. Opt.* **12**, 555-563 (1973).
- S. Wray, M. Cope, D. T. Delpy, J. S. Wyatt, and E. O. R. Reynolds, "Characterization of the near infrared absorption spectra of cytochrome *aa*<sub>3</sub> and haemoglobin for the non-invasive monitoring of cerebral oxygenation," *Biochim. Biophys. Acta* **933**, 184-192 (1988).
- F. Sakai, K. Nakazawa, Y. Tazaki, K. Iishi, H. Hidetada, H. Igarishi, and T. Kanda, "Regional cerebral blood volume and hematocrit measured in normal human volunteers by single photon emission computed tomography," *J. Cerebr. Blood Flow Met.* **5**, 207-213 (1985).
- H. Miyake, S. Nioka, A. Zaman, D. S. Smith, and B. Chance, "The detection of cytochrome oxidase heme iron and copper absorption in the blood-perfused and blood-free brain in normoxia and hypoxia," *Anal. Biochem.* **192**, 149-155 (1991).
- M. Miwa, Y. Ueda, and B. Chance, "Development of time resolved spectroscopy system for quantitative non-invasive tissue measurement," *Proc. SPIE* **2389**, 142-149 (1995).
- M. Ferrari, R. A. De Blasi, S. Fantini, M. A. Franceschini, B. Barbieri, V. Quaresima, and E. Gratton, "Cerebral and

- muscle oxygen saturation measurement by a frequency-domain near-infrared spectroscopic technique," *Proc. SPIE* **2389**, 868–874 (1995).
27. V. Quaresima, A. Pizzi, R. A. De Blasi, A. Ferrari, M. De Angelis, and M. Ferrari, "Quadriceps oxygenation changes during walking and running on a treadmill," *Proc. SPIE* **2387**, 249–256 (1995).
  28. Y. Yamashita, M. Oda, H. Naruse, and M. Tamura, "In Vivo measurement of reduced scattering coefficient and absorption coefficient of living tissue using time-resolved spectroscopy," in *OSA Trends in Optics and Photonics on Advances in Optical Imaging and Photon Migration*, Vol. 2, pp. 387–390, R. R. Alfano and J. G. Fujimoto, Eds., Optical Society of America, Washington, DC (1996).
  29. B. J. Tromberg, O. Coquoz, J. B. Fishkin, E. R. Anderson, D. Pham, M. Brenner, and L. O. Svaasand, "Frequency-domain photon migration (FDPM) measurements of normal and malignant cell and tissue optical properties," in *OSA Trends in Optics and Photonics on Biomedical Optical Spectroscopy and Diagnostics*, Vol. 3, pp. 111–116, E. Sevick-Muraca and D. Benaron, Eds., Optical Society of America, Washington, DC (1996).
  30. Francis A. Duck, *Physical Properties of Tissues: a Comprehensive Reference Book*, pp. 320–321, Academic Press, San Diego, CA (1990).